

Omega Design's

HFPO

Horizontal Fifth Panel Orienter

Fully automatic, variable speed carton orienter. Packing made simple.



- Nest fifth panel cartons into packs
- Orient cartons 180 degrees within a pack
- Easy to operate and maintain
- Central lubrication
- Fully automatic operation
- Rapid, repeatable changeovers

240

Bottles per minute



Changeover



FDA-Approved Belts



ounce
to
gallon

Ideal applications: bottles, tottles, jars, tubes, vials, jugs, other

** Speed and changeover will vary per customer's application and options selected.*

★★★★★
MADE IN THE USA

Since 1969

www.omegadesign.com

Tel: 1 (610) 363-6555

OMEGA
DESIGN CORPORATION

HFPO

Horizontal Fifth Panel Orienter

Our Value Promise
www.omegadesign.com/value



UTILITIES:

- Voltage: 208/240/480 VAC, 50/60 Hz
- Air: 8-24 SCFM @ 80 psig
- Utilities may vary per client specifications

CONTROLS:

- Allen Bradley PLC
- Allen Bradley Touch Screen HMI

STANDARD FEATURES:

- Electrical safety Interlocks and guards
- Steel frame with painted protective coating
- Central lubrication
- Leveling legs
- Swingarm for HMI

OPTIONS:

- Frame upgrade to stainless steel
- Casters
- UL panel
- Validation support documentation

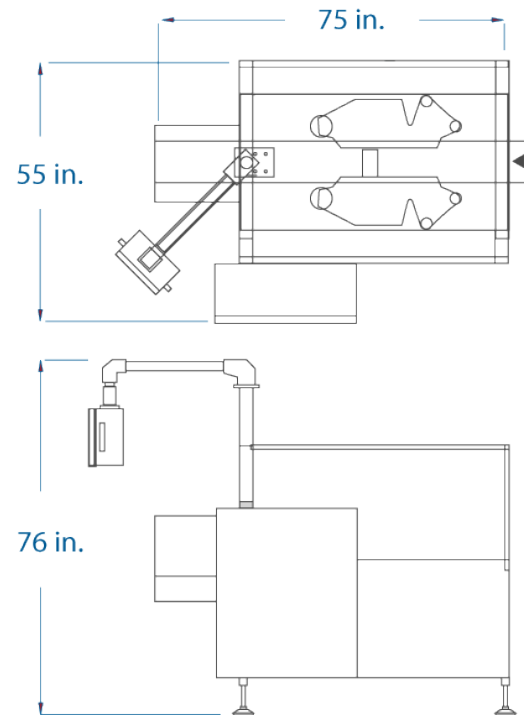

* Layout and dimensions may vary per application.

OPERATION:

An operator loads a machine recipe. Fifth panel cartons enter the machine on a conveyor. Side belts space and release the cartons per the recipe's pack sequence. If a carton needs to be rotated 180 degrees, then it will engage a trip cylinder. Cartons get nested together and conveyed away as a pack.

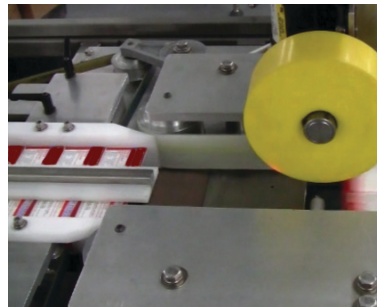
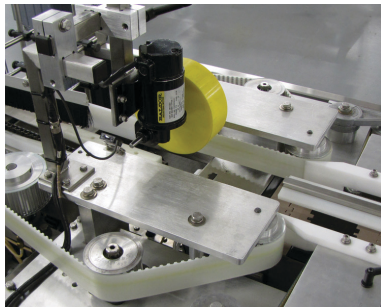

Reminder Ask about our excellent track record of on-time deliveries and industry-leading FATs. Better yet, read what our clients have to say: www.omegadesign.com/testimonials

